

Q870M-IM-A

Micro ATX, Intel® Core™ Ultra Processors(Series 2), LGA1851, Q870 Chipset, 4*U-DIMM, 2*Lan, 2*PCIe x16 slots, 2*HDMI, 2* DP, 2*M.2 slot, 6*COM, 4*SATA

Features

- Support up to 125W Intel® Core™ Ultra Processors(Series 2)
- Four U-DIMM up to 192GB DDR5 5600 MHz
- Supports multiple displays: HDMI / DP
- Dual M.2 M key supports NVMe
- 7-year longevity supply

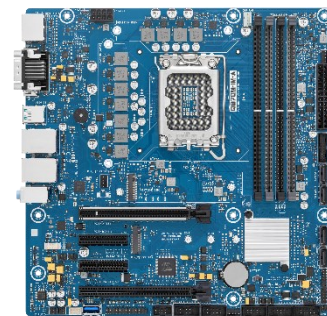

Specifications

Processor System	CPU	LGA1851 for Intel® Core™ Ultra Processors(Series 2) Max. 125W TDP
	Chipset	Intel® Q870 Chipset
Memory	Technology	DDR5 5600MT/s (SPC 0r2r) 4400MT/s (2SPC 2r2r)
	Max.	192GB
	Socket	4 x U-DIMM
Display	Display Port	2, Supports DP 1.4(DP++), up to 4096 x 2160 @ 60Hz
	HDMI	2, Supports 2.1, up to 4096 X 2160 @ 60Hz
	Multiple displays	Max.4 displays
Expansion Slot	PCIe	1 x PCIe 5.0 x16 Slot (1 x16 mode/ 2 x8 mode) 1 x PCIe 4.0 x16 Slot (x4 mode) 1 x PCIe 4.0 x4 Slot (x4 mode) 1 x PCIe 4.0 x4 Slot (x4 mode)
	M.2	1 x M.2 M key, Type 2242/2260/2280 (PCIe 4.0 x4 mode) supports NVMe 1 x M.2 M key, Type 2280 (PCIe 5.0 x4 mode) supports NVMe
Ethernet	Speed	10/100/1000/2500 Mbps
	Controller	1 x Intel® i210AT 1 x Intel® i226LM (Intel vPro supported)
	Connector	2 x RJ-45
Audio	Codec	Realtek ALC897
Storage	SATA port	4 x SATA Gen 3.0, Up to 6Gb/s, Support RAID 0,1,5,10
Rear I/O	Display Port	2 x HDMI™ ports
	HDMI	2 x DisplayPort
	USB 3.2 Gen2	2 x type A
	USB 3.2 Gen1	4 x type A
	Ethernet	2 x RJ45
	Serial Port	1 (RS232/422/485)
	Audio jack	3 (Line-Out, Line-In, Mic in)

Block Diagram

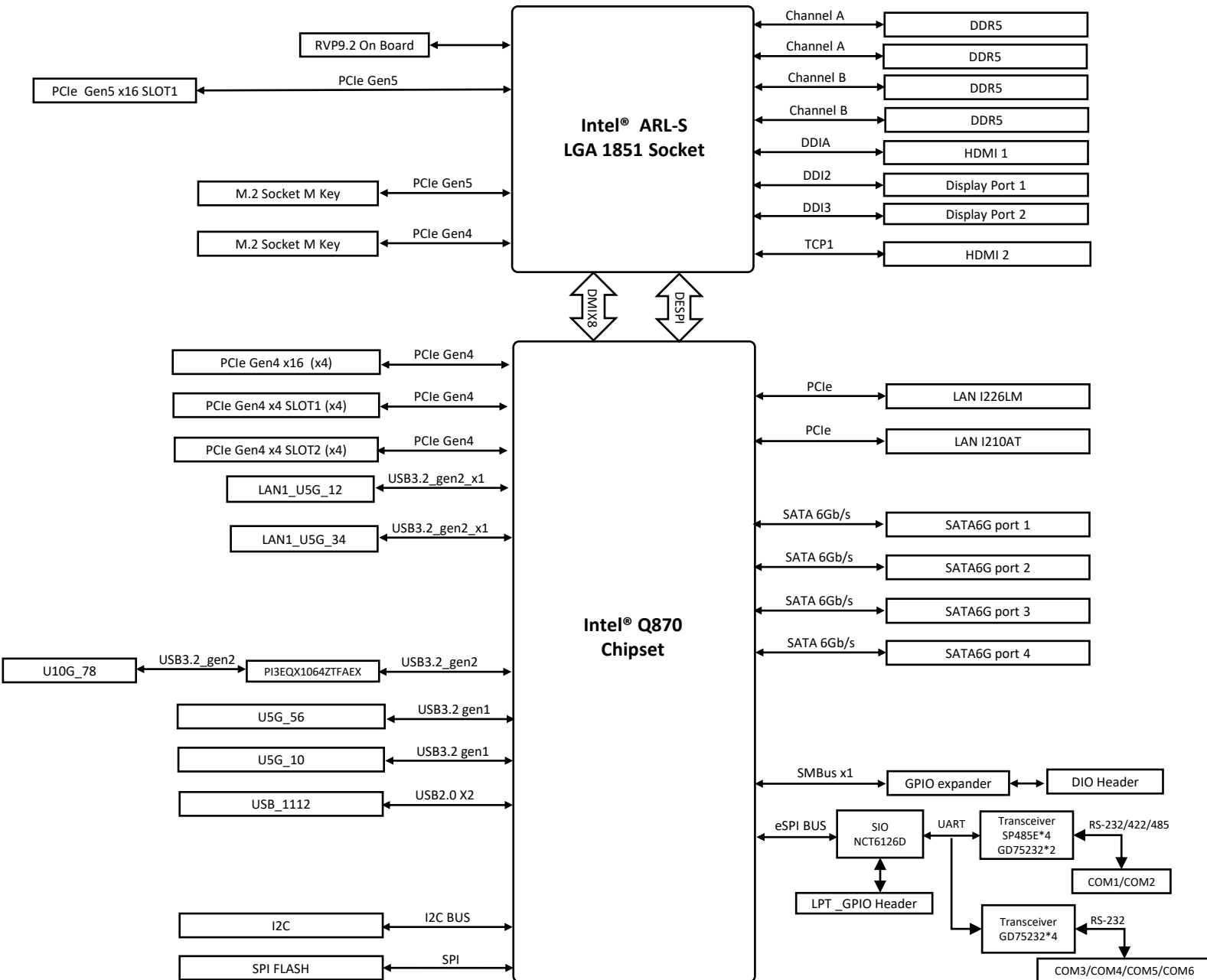

Order Information

Model name	Part number	Description
Q870M-IM-A	90ME0AG*	LGA1851,Q870,HDMI,DP,COM,MB

* The part number might vary for different regulations and package. Please consult the TPM in your region for exact 90PN.

Packing List

Part number	Description	Quantity
13020*	IO shield	1
14013*	SATA 6G CABLE	1
13020*	M.2 SCREW PACK	1

* The part number might vary due to part number revision.