

P1507D-MT



Fanless 15" XGA 4:3 Industrial Panel PC with Intel 8th Core i-3 / i5 / i7 Processor



Features

- 15" 4:3 1024 x 768 XGA LCD Display w/ LED Backlight
- Flat panel with projected capacitive touchscreen, 10 points Multi
- Front panel compliant with IP65
- Anti-scratch surface: 7H hardness
- Easy Maintenance Design for CFast/HDD/SSD
- Serial Ports (RS-232/485), RS-485 w/ Auto-flow Control
- Mini PCIe expansion slot support
- Fanless cooling system
- 1x TPM Module (optional)
- SMA Antenna Holes for Optional WiFi Function
- 12 ~ 24V Wide-Range DC Input

System	
CPU	Intel® Gen. Whisky Lake, CPUs Intel®Core i5-8265U™CPU 1.6 - 3.9GHz, 6MB Intel®Core i3-8145U™CPU 2.1 - 3.9GHz, 4MB
Memory	1 x DDR4L SO-DIMM Socket, supporting 2400 MHz SDRAM up to 16GB
LAN	1 x Intel®211AT 1x 219V GbE controllers
Watchdog Timer	1~255 levels reset
Storage	
1st Device	2 x 2.5" drive bay, Raid 0,1,5(optional)
2nd Device	mSATA, mPCIe, M.2
Audio	
Speaker	No
LCD Display	
Size/Type	15" TFT LCD Panel
Max. Resolution	1024 x 768 XGA
Max. Colors	16.2M
Luminance	300 cd/m ²
Touch Screen	Projected capacitive touch panel, 10 points Multi
View Angle (U/D/R/L)	80°/80°/85°/85°
Power System	
Power Input	DC 12~24V
& H U W L ĵ F D W L R Q	
EMC / EMI	Meet CE, FCC Class A
([S D Q V L R Q	
Expansion Bus	1 x Mini-card socket (Full Size)

[W H U Q D O , 2	
Serial Ports	2 x RS-232 (4 x RS-232 optional)
USB Ports	4 x Type-A USB 3.0 ports 2x USB 2.0 port (4x USB 2.0 optional)
LAN	2 x RJ-45 GbE ports
Graphics	1 x HDMI / DP connector
WiFi	optional
0 H F K D Q L F D O	
Mounting Type	Panel Mounting and VESA-100 Mounting
Chassis	Panel-mounting chassis, aluminum front bezel and SECC steel chassis
Dimension (W x D x H)	410 x 54 x 310 mm
Weight (Net)	6 kg
(Q Y L U R Q P H Q W D O	
Operating Temp.	-20°C ~ 60°C
Storage Temp.	-30°C ~ 70°C (-22°F ~ 158°F)
Operating Humidity	10 ~ 95% RH @ 60°C (non-condensing)
Vibration	5 ~ 500Hz, 2Grms Random (with CFast/SSD)
Shock	Operating 10G, 11ms Non-operating 30G, 11ms (with CFast/SSD)
2 6 6 X S S R U W	
W 10 / Win 10 IOT Enterprise	
Linux Kernal 4.x, Ubuntu 16.04, Fedora 25+	

Alptech Elektronik GmbH

Computer für Industrie
Computer for Industry

Powered by ASUS



P1507D-MT

Fanless 15" XGA 4:3 Industrial Panel PC with Intel® 8th Core i-3 / i5 / i7 Processor

Dimensions

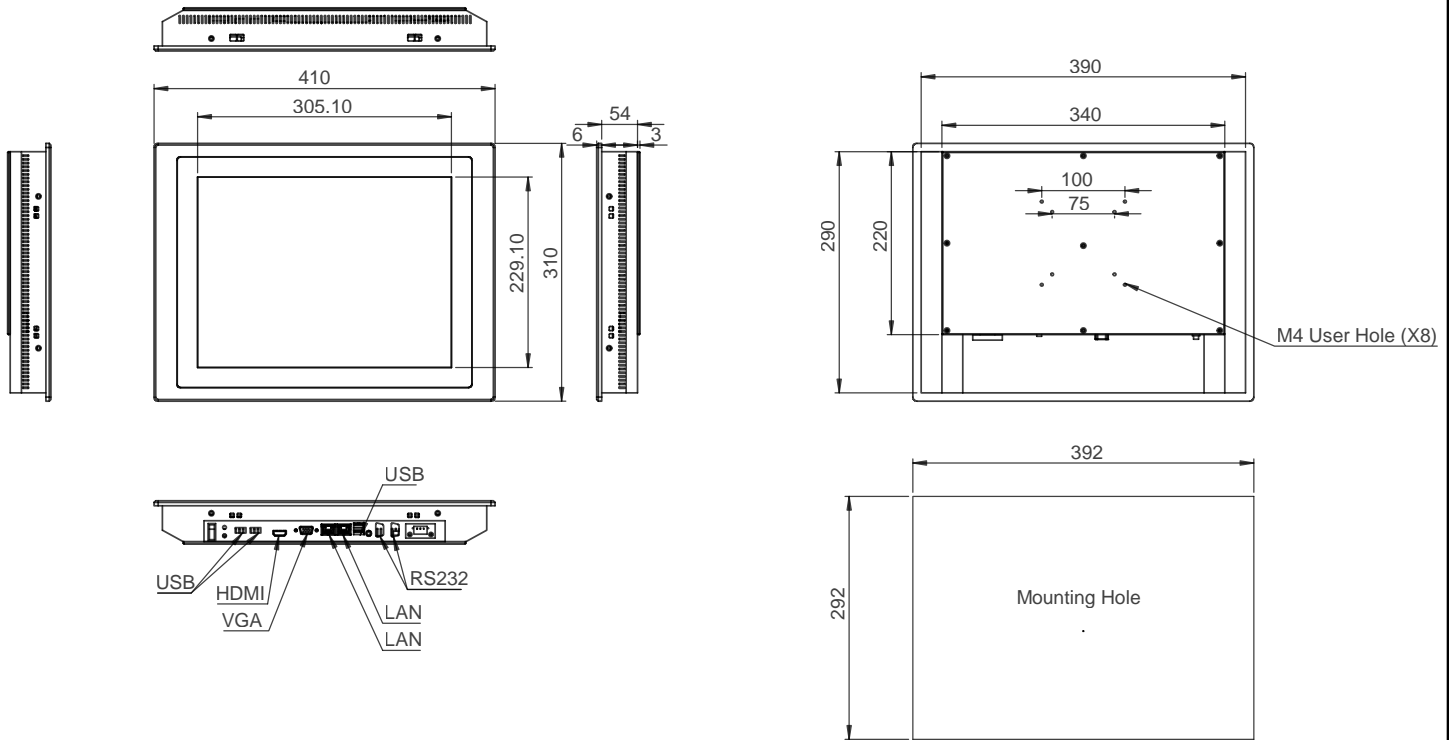

Unit : mm

Optional Accessories

PAC-P065/120W 19V/3.4A 65W /120WAC/DC power adapter kit



Optional Configuration (CTOS* Kit)

WIFI-AT2350 Atheros AR9462 WiFi module w/ 20cm & 30cm internal wiring



ANT-D11 1 x WiFi Dual-band 2.4G/5G antenna



www.alptech.de

Alptech Elektronik GmbH

*CTOS means Configure-to-Order Service.