

# Gladius G1052C



## 10.4" Intel® Celeron® N2930 Rugged Tablet PC

## Multi Touch



### Features

- 10.4" AFFS+ TFT Active Matrix with Capacitive Touch Panel, Multi Touch
- Ultra Low Power Consumption
- Fully Rugged for Mobile POS or Warehousing Application
- Meeting MIL-STD-810F, IP54, 4 ft. Drop Resistance
- High Mobility, Multiple Connectivity (Bluetooth/WLAN/WWAN)
- Identification Devices (Barcode Scanner, RFID Reader and MSR)
- Hot-swappable external battery w/ redundant internal battery
- 23-key Keypad with Numeric Keys and Function Keys
- I.P.A. (Isopropyl) Alcohol Clearing Allowed

System	
CPU	Intel® Celeron® Processor N2930 quad-core 1.86 GHz
Graphics Controller	Intel® HD Graphics
Memory	2GB DDR3L SO-DIMM memory module installed (optional up to 8GB)
Chipset	Intel® System Controller Hub US15WP
BIOS	UEFI BIOS
Audio	1 x Integrated microphone
	1 x Integrated 2W speaker
	1 x Earphone jack
Storage	1 x 32GB mSATA SSD, upto 256GB optional
Peripherals and Devices	
Camera	5.0 MP rear camera with Auto Focus (optional ) Integrated 13.56MHz, ISO 15693/14443A/ 14443B RFID Reader (distance: 3~5cm; speed: 5 cards/sec) (optional)
RFID	
WLAN	Integrated WLAN 802.11 a/b/g/n
Bluetooth	Integrated Bluetooth 4.0 BLE, class 2
WWAN	HSUPA / HSPA+ / LTE (optional)
Barcode Scanner	1 x 1D/2D Barcode scanner (optional)
MSR	Integrated Magnetic Stripe Reader (optional)
Smart Card Reader	Smart Card Reader (optional)
GPS	U-BLOX 6 GPS Receiver (optional)
I/O Interface	
USB Port	1 x USB 3.0/2.0 Type-A port
SD Card	1 x SD/SDHC/SDXC slot
Docking Port	1 x 35-pin pogo connector for docking connection
Expansion	1 x USB 2.0 Type-A or USB Sensor Hub
Button & Indicator	
Function Key	10 x Numeric keys (0 ~ 9); 1 x Ctrl key; 1 x Enter key; 1 x Backspace; 1 x 4-way navigation key; 1 x Dot (.) key; 4 x Function keys; 1 x Brightness key;
Power Button	1 x Power on/off button
LED Indicator	1 x Battery LED
	1 x WLAN/RFID LED
	1 x Bluetooth/WWAN LED
Touch Screen	
Type	10-Point Projected Capacitive Touch with Corning® Gorilla Glass, Multi Touch Projected Capacitive Touch for G1052C
Light Transparency	80% (typ.)
Controller Interface	USB Interface

LCD Display	
Size/Type	10.4" XGA TFT color LCD with LED backlight
Max. Resolution	1024 x 768 (XGA) w/ 262,144 colors
Luminance	340 cd/m <sup>2</sup> (typ.)
	600 :1
Contrast Ratio	89°/89°/89°/89°
View Angle (U/D/R/L)	LED
Backlight Type	LED
Power Supply	
Adapter Input	100 ~ 240VAC (Full Range)
Adapter Output	19VDC, 3.42A, 65W
Battery Type	Li-battery pack
Battery Capacity	1 x 1880mAh 3-cell internal battery pack (optional)
	1 x 2500mAh 4-cell external battery pack
Battery Operating Time	6 hours (typ.)
Mechanical & Environmental	
Operating Temp.	-20 ~ 45°C (-4 ~ 113°F)
Storage Temp.	-20 ~ 60°C (-4 ~ 140°F)
Discharging Temp.	-20 ~ 45°C (-4 ~ 113°F)
Charging Temp.	0 ~ 40°C (32 ~ 104°F)
Operating Humidity	10 ~ 95% @ 45°C (non-condensing)
Dimensions (W x D x H)	205 x 294 x 25 mm (8.07" x 11.57" x 0.98")
Gross Weight	1.2 kg (2.64 lb)
	20 to 1000 Hz @ 1 grms per MIL-STD 810G (operating)
Vibration	20 to 1000 Hz @ 3 grms per MIL-STD 810G (non- operating)
	11 ms @ 20G per MIL-STD 810G for unit only (operating)
Shock	11 ms @ 40G per MIL-STD 810G for unit only (non- operating)
Transit Drop	1.2m (4ft.) (whole unit)
IP Rating	IP54 (whole unit)
Regulatory	CE: EN55022 class B
	FCC 47 CFR, Part 2 and Part 15
OS Support	
Windows Embedded 7 / Windows 7 Professional	
Windows 8.1 Embedded / Windows 8.1 Professional	
Ordering Information	
G1052C	10.4" Intel® Celeron® N2930 rugged tablet PC with projected capacitive touch, battery pack, WLAN and Bluetooth
G1052CS	10.4" Intel® Celeron® N2930 rugged tablet PC with projected capacitive touch, battery pack, WLAN and Bluetooth, and sunlight readable display (800 nits)

Alptech Elektronik GmbH



Zimmersmühlenweg 14-18 Tel: 06171-9799110 E-Mail: info@alptech.de

D-61440 Oberursel/Ts. Fax: 06171-9799115 www.alptech.de



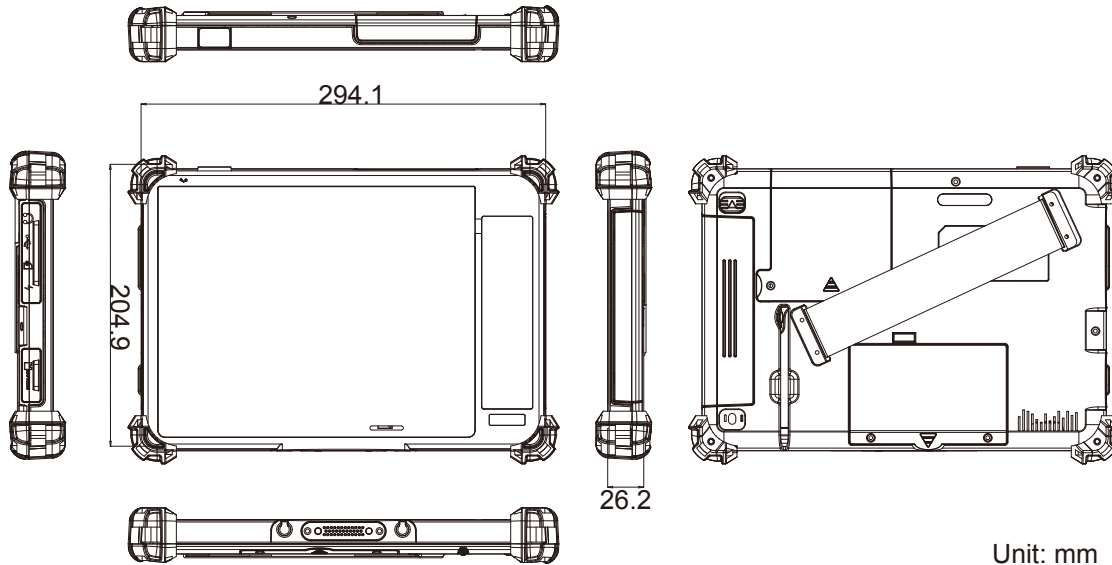





## Dimensions











### Standard Accessories

Power Adapter	19V/3.42A 65W AC/DC Adapter Kit	
Hand Strap	212mm Black Elastic Hand Strap	
eBAT-1050	2500mAh External Battery Pack	

### Optional Accessories

Power Adapter	19V/3.42A 65W AC/DC Adapter Kit	
SST-0720	Shoulder Strap, 128 x 3.7cm	
eBAT-1050	2500mAh External Battery Pack	
iBAT-1040	3-Cell 1880mAH Internal Battery kit	
NST-1050	Neck Strap, 120 x 4 x 0.6 cm (G1050 Series Only)	
VSB-100	VESA-75 to VESA-100 Adapter Bracket	
VMB-1050	VESA Mount Bracket for G1050	
DTC-1050	Desktop Cradle for G1050/G1050S	
CHR-1050	Dual-Bay External Battery Charger	

### Optional Configuration (CTOS\* Kit) (Not Sold Separately)

UDG-1050	USB Dongle Kit	
RFID-1050	13.56MHz RFID Kit	
BarC-1050	1D/2D Barcode Scanner Kit	
HSUPA-1050	3.75G HSUPA Wireless Kit	
GRS-1050	GPS and RS-232 2in1 Kit	
SRS-1050	Smart Card Reader and RS-232 2in1 Kit	
MSR-1050	MSR Module Kit	
RFID/NFC-1050	13.56MHz RFID/NFC Kit	
CAM-1052	5.0M Rear CMOS Camera Kit	

\*CTOS means Configure-to-Order Service.  
All specifications are subject to change without notice.

\*The GRS, SRS and MSR cannot co-exist on the computer as they occupy the same installation position. Please select any one of them.